

USER'S MANUAL

Duct Type Air Conditioner

MODEL

DBIS-09 DBIS-12
DBIS-18 DBIS-24

Thank you for choosing our product.

For proper operation, please read and keep this manual carefully.

Content

Safety Precautions.....	1
Installation Location and Matters Needing Attention.....	5
How to select the installation location for the indoor unit.....	5
Electric wiring.....	5
Earthing Requirements.....	6
Outline of the Unit and Main Parts.....	6
Accessories for installation.....	7
Installation Instructions.....	8
Outline Dimension Drawings of the Indoor Unit.....	8
Dimension Requirements on the Installation Space of the Indoor Unit.....	9
Installation of the Indoor Unit.....	9
Installation of the Connection Pipe.....	11
Installation of the Drain Hose.....	14
Installation of the Duct.....	16
Filter Installation.....	18
Electrical Wiring.....	19
Installation of the Wired Controller.....	21
Test Running.....	22
Trial Operation and Testing.....	22
Rated Working Conditions.....	23
Indoor unit address inquiry.....	23
Error Analysis.....	24
Maintenance.....	25



This marking indicates that this product should not be disposed with other household wastes throughout the EU. To prevent possible harm to the environment or human health from uncontrolled waste disposal, recycle it responsibly to promote the sustainable reuse of material resources. To return your used device, please use the return and collection systems or contact the retailer where the product was purchased. They can take this product for environmental safe recycling.

Safety Precautions

Please read this manual carefully before using and operating correctly as instructed in this manual.

Please especially take notice of the following two symbols:



WARNING!

It indicates improper operation which will lead to human casualty or severe injury.



CAUTION!

It indicates improper operation which will lead to human casualty or severe injury.

USER NOTICE

This appliance can be used by children aged of 8 years and above and persons with reduced physical, sensory or mental capabilities or lack of experience and knowledge if they have been given supervision or instruction concerning use of the appliance in a safe way and understand the hazards involved.

Children shall not play with the appliance.

Cleaning and user maintenance shall not be made by children without supervision.

The total capacity of the indoor units which runs at the same time can not exceed 150% of that of the outdoor units, otherwise, the cooling (heating) effect of each indoor unit would be poor.

Switch the main power on 8 hours before starting the unit, helpful for a successful startup.

It is a normal phenomenon that the indoor unit fan will still run for 20~70 seconds after the indoor unit receives the “stop” signal so as to make full use of after-heat for the next operation.

Safety Precautions

When the running modes of the indoor and outdoor units conflict, it will be indicated on the display of the wired controller in five seconds and then the indoor unit will stop. In this case, they can back to the normal condition by harmonizing their running modes: the cooling mode is compatible with the dehumidifying mode and the fan mode can go with any other mode except the heating mode. If the supply power fails when the unit is running, then the indoor unit will send the “start” signal to the outdoor unit three minutes later after power recovery.

During installation, the communication cable and the power cord must not be twisted together but instead separated with an interval of at least 2cm, otherwise the unit is likely to run abnormally.

This appliance is not intended for use by persons (including children) with reduced physical, sensory or mental capabilities, or lack of experience and knowledge, unless they have been given supervision or instruction concerning use of the appliance by a person responsible for their safety. Children should be supervised to ensure that they do not play with the appliance.

The appliance shall be installed in accordance with national wiring regulations.

If the supply cord is damaged, it must be replaced by the manufacturer, its service agent or similarly qualified persons in order to avoid a hazard.

Safety Precautions

WARNING!

The installation should be committed to the appointed service center, otherwise it will cause water leakage, electric shock or fire etc..

Please install the unit in a place where is strong enough to withstand the weight of the unit, otherwise, the unit would fall down and cause injury or death.

The drain pipe should be installed as instructed in the manual to guarantee the proper drainage, meanwhile it should be insulated to prevent condensing. Otherwise the improper installation would cause water leakage and then wet the household wares in the room.

Do not use or place any inflammable, combustible or any noxious substance next to the unit.

Under the occurrence of an error (like burning smell etc.), please cut off the main power supply of the unit.

Keep good ventilation in the room to avoid oxygen deficit.

Never insert your finger or any other object into the air outlet/inlet grille.

Please take notice of the supporting frame of the unit to see if it is damaged over the long time period of use.

Never refit the unit and contact the sales agent or the professional installation personnel for the repair or relocation of the unit.

Non-professional personnel are prohibited to dismantle of the electric box owing to the high voltage of the outdoor unit.

An all-pole disconnection switch having a contact separation of at least 3mm in all poles should be connected in fixed wiring.

Safety Precautions



Before installation, please check if the power supply corresponds with the requirement specified on the nameplate and also check its security.

Before using the unit, please check if the piping and wiring are correct to avoid water leakage, refrigerant leakage, electric shock, or fire etc.

The main power supply must be earthed to avoid the hazard of electric shock and never connect this earth wire to the gas pipe running water pipe, lightning rod or phone cable's earth lead.

Turn off the unit after it runs at least five minutes, otherwise its service life will be shortened.

Do not allow children operate this unit.

Do not operate this unit wet hands.

Cut off the main power supply prior to the cleaning of the unit or the replacement of the air filter.

When the unit is not to be used for a long time, please cut off the main power supply of the unit.

Do not expose the unit to the moist or corrosive circumstances.

After the electric installation, please take an electric leakage test.

Installation Location and Matters Needing Attention

The installation of the unit must comply with the national and local safety regulations. The installation quality directly affects the normal use, so the user should not carry out the installation personally, instead, the installation and debugging should be done by technician according to this manual. Only after that, can the unit be energized.

How to select the installation location for the indoor unit

1. Where there is no direct sunlight.
2. Where the top hanger, ceiling and the building structure are strong enough to withstand the weight of the unit.
3. Where the drain pipe can be easily connected to outside.
4. Where the flow of the air inlet/outlet is not blocked.
5. Where the refrigerant pipe of the indoor unit can be easily led to outside.
6. Where there is no inflammable、explosive substances or their leakage.
7. Where there is no corrosive gas、heavy dust、salt mist、smog or moisture.



CAUTION!

The unit installed in the following places is likely to run abnormally .if unavoidable, please contact the professional personnel at the SKYWORTH appointed service center.

- Where is full of oil.
- Alkaline soil off the sea.
- Where there is sulfur gas (like sulfur hot spring).
- Where there are devices with high frequency (like wireless devices, electric welding devices, or medical equipment).
- Special circumstances.

Electric wiring

1. The installation must be done in accordance with the national wiring regulations.
2. Only the power cord with the rated voltage and exclusive circuit for the air conditioning can be used.
3. Do not pull power cord by force.
4. The electric installation should be carried out by the professional personnel as instructed by the local laws, regulations and also this manual.
5. The diameter of the power cord should be large enough and once it is damaged It must be replaced by dedicated one.
6. The earthing should be reliable and the earth wire should be connected to the dedicated device of the building by the professional personnel. Besides, the air switch coupled with the leakage current protection switch must be equipped, which is of enough capacity and of both magnetic and thermal tripping functions in case of the short circuit and overload.

Installation Location and Matters Needing Attention

Earthing Requirements

1. The air conditioner is classified into the class I appliances, so its earthing must be reliable.
2. The yellow-green line of the air conditioner is the earth line and can not be used for other purpose, cut off or fixed by the tapping screw, otherwise it would cause the hazard of the electric shock.
3. The reliable earth terminal should be provided and the earth wire cannot be connected to any of the following places.
 - (1) Running water pipe
 - (2) Coal gas pipe
 - (3) sewage pipe
 - (4) other places where the professional personnel think unreliable

Outline of the Unit and Main Parts

• Indoor

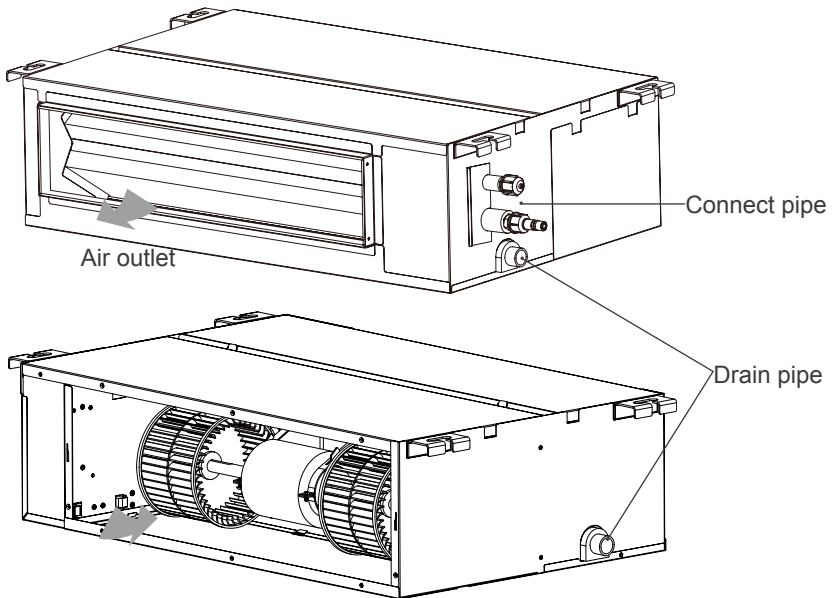

• Wired Controller



NOTE:







- The connection pipe and duct for this unit should be prepared by the user.
- The unit is standard equipped with rectangular duct.

Installation Location and Matters Needing Attention

Accessories for installation

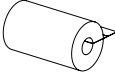
The standard accessory parts listed below are furnished and should be used as required.

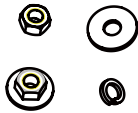
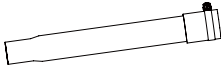
Table 1

	Name	Appearance	Q'ty	Usage
Indoor Unit	Wired Controller		1	To control the indoor unit
	Screw		2	To install the wired controller
	Insulation		2	To insulate the drain pipe
	Insulation		2	To insulate the gas and liquid pipe
	Corrugated pipe		2	Only for 24 unit
	Nut		1 or 2	Only one for 24 unit
	Nut		4	To install the indoor unit
	Drain pipe		1	
	Fastener		6	To fasten the sponge
	Others	Instructions、bar code		

Installation Instructions

Outline Dimension Drawings of the Indoor Unit

Note: the unit in the followings is mm, unless otherwise specified.

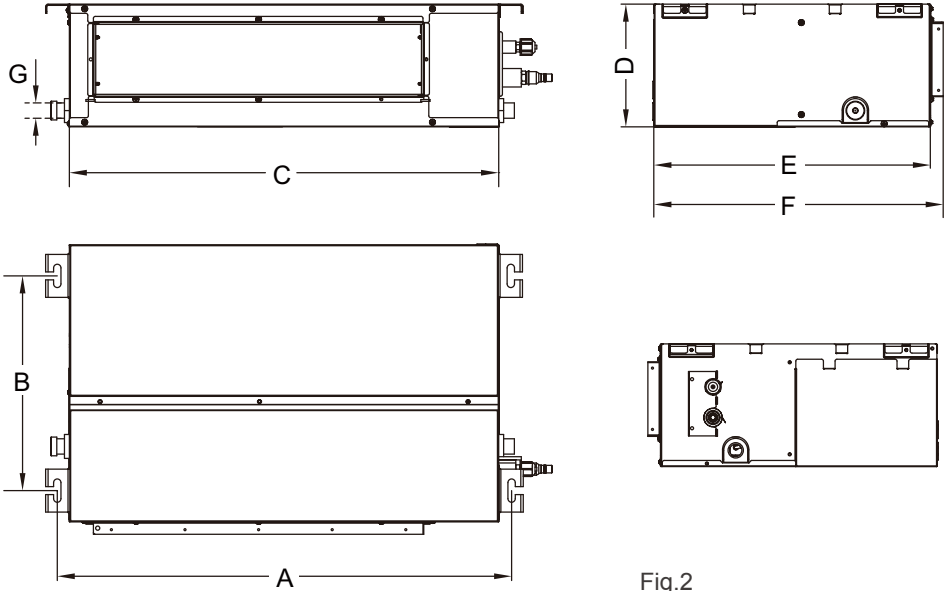

Fig.2

Table 2 : Outline Dimensions

Model \ Item	A	B	C	D	E	F	G
DBIS-09	740	350	700	200	450	472	26
DBIS-12	740	350	700	200	450	472	26
DBIS-18	1040	350	1000	200	450	472	26
DBIS-24	1340	350	1300	200	450	472	26

Installation Instructions

Dimension Requirements on the Installation Space of the Indoor Unit

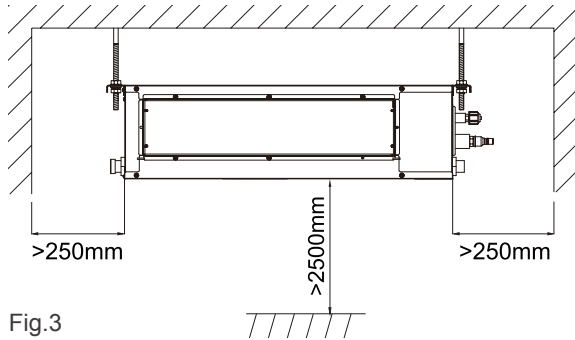

Installation of the Indoor Unit

a. Requirements on the Installation Location

1. Ensure the hanger is strong enough to withstand the weight of the unit.
2. The drainage of the drain pipe is easy.
3. No obstacle is in the inlet/outlet and the air circulation in good condition.
4. Ensure the installation space shown in Fig.3 is left for the access to maintenance.
5. It should be far away from where there is heat source, leakage of inflammable, explosive substances, or smog.
6. It is the ceiling type unit(concealed in the ceiling)
7. The power cords and connection lines of the indoor and outdoor units must be at least 1m away from the TV set or radio to avoid the image interference and noise (even if 1m is kept, the noise may be produce due to the strong electric wave)

b. Installation of the indoor unit

1. Drilling Holes for Bolts and Installing the Bolts

Using the installation template, drill holes for bolts (four holes). (Fig.4)

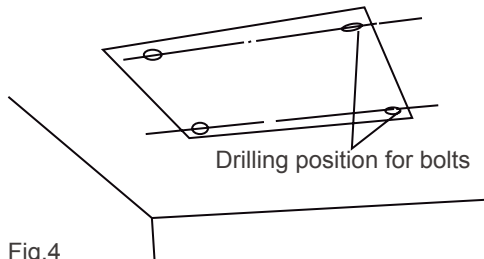

Installation Instructions

2. Installing the Suspension Bolts

- (1) Install the bolts to the ceiling at a place strong enough to hang the unit. Mark the bolt positions from the installation template. With a concrete drill, drill for 12.7mm (1/2") diameter holes. (Fig. 5)
- (2) Insert the anchor bolts into the drilled holes, and drive the pins completely into the anchorbolts with a hammer. (Fig. 6)
- (3) Install the hanger to the unit.
- (4) Pass the unit hangers over the bolts installed to the ceiling and install the unit with the special nut. (Fig.7)

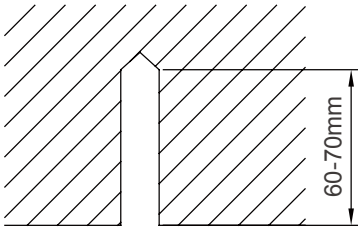

Fig.5

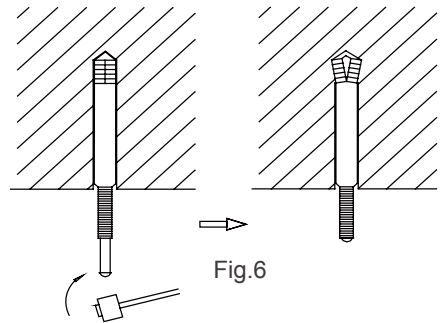

Fig.6

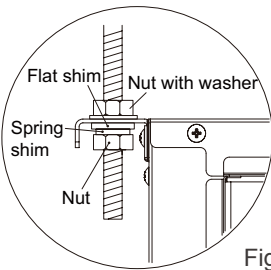
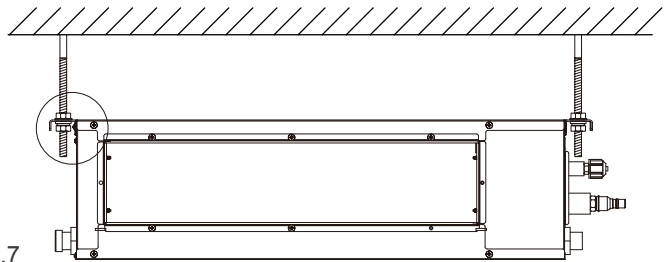

Fig.7



3. Horizontal Check of the Indoor Unit

After the installation of the indoor unit, its horizontal must be checked to make sure the unit keep horizontal fore and aft and keep an inclination of 1° toward the drain pipe right and left, as show in Fig.8.

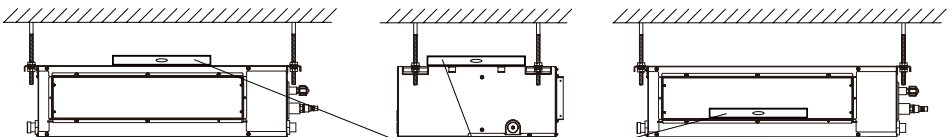

Fig.8

Horizontal tester

Installation Instructions

CAUTION!

- Prior to the installation, please make a good preparation for all piping (refrigerant pipe, drain pipe) and wiring (wires of the wired controller, wires between the indoor and outdoor unit) of the indoor unit to make the further installation much easy.
- If there is an opening in the ceiling, it is better to reinforce it to keep it flat and prevent it vibrating. Consult the user and builder for more details.
- If the strength of the ceiling is not strong enough, a beam made of angle iron can be used and then fix the unit on it.
- If the indoor unit is not installed in the air conditioning area, please use sponge around the unit to prevent condensing. The thickness of the sponge depends on the actual installation environment.

Installation of the Connection Pipe

a. Flare Processing

1. Cut the connection pipe with the pipe cutter and remove the burrs.
2. Hold the pipe downward to prevent cuttings from entering the pipe.
3. Remove the flare nuts at the stop valve of the outdoor unit and inside the accessory bag of the indoor unit, then insert them to the connection pipe, after that, flare the connection pipe with a flaring tool.
4. Check if the flare part is spread evenly and there are no cracks (see Fig.9).

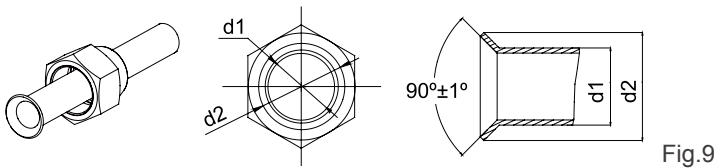

b. Bending Pipes

1. The pipes are shaped by your hands. Be careful not to collapse them.

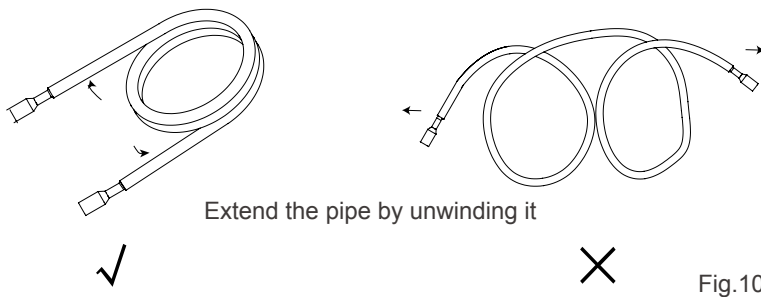

Installation Instructions

2. Do not bend the pipes in an angle more than 90°.
3. When pipes are repeatedly bent or stretched, the material will harden, making it difficult to bend or stretch them any more. Do not bend or stretch the pipes more than three times.
4. When bending the pipe, do not bend it as is. The pipe will be collapsed. In this case, cut the heat insulating pipe with a sharp cutter as shown in Fig.14, and bend it after exposing the pipe. After bending the pipe as you want, be sure to put the heat insulating pipe back on the pipe, and secure it with tape.

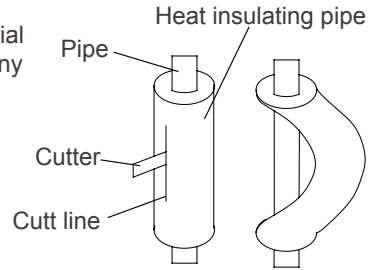

Fig.11

CAUTION!

- To prevent breaking of the pipe, avoid sharp bends. Bend the pipe with a radius of curvature of 150 mm or over.
- If the pipe is bent repeatedly at the same place, it will break.

c. Connecting the Pipe at the Indoor Unit Side

Detach the caps and plugs from the pipes.

CAUTION!

- Be sure to apply the pipe against the port on the indoor unit correctly. If the centering is improper, the flare nut cannot be tightened smoothly. If the flare nut is forced to turn, the threads will be damaged.
- Do not remove the flare nut until the connection pipe is to be connected so as to prevent dust and impurities from coming into the pipe system.

Centering the pipe against port on the indoor unit, turn the flare nut with your hand.

CAUTION!

Hold the torque wrench at its grip, keeping it in the right angle with the pipe as shown in Fig. 12, in order to tighten the flare nut correctly.

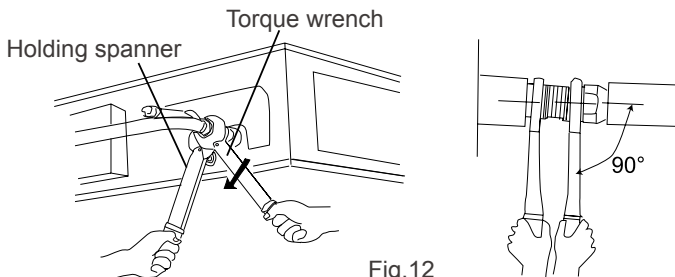

Fig.12

Installation Instructions

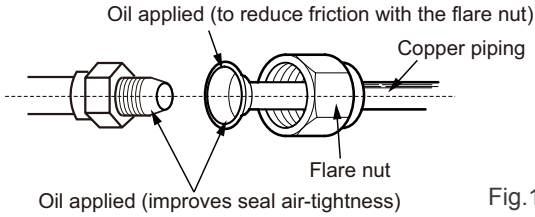

Fig.13

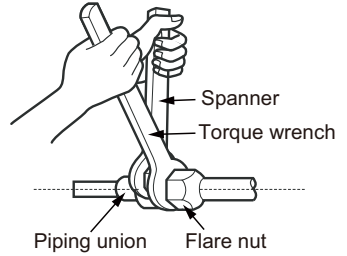

Table 3 Flare nut tightening torque

Pipe Diameter (Inch)	1/4"	3/8"	1/2"	5/8"	3/4"	7/8"
Tightening Torque (N·m)	15-30	35-40	45-50	60-65	70-75	80-85

CAUTION!

Be sure to connect the gas pipe after connecting the liquid pipe completely.

d. Checking the Pipe Connections for Gas Leaking

For both indoor and outdoor unit side, check the joints for gas leaking by the use of a gas leakage detector without fail when the pipes are connected.

e. Heat Insulation on the Pipe Joints

Stick coupler heat insulation (large and small) to the place where connecting pipes.

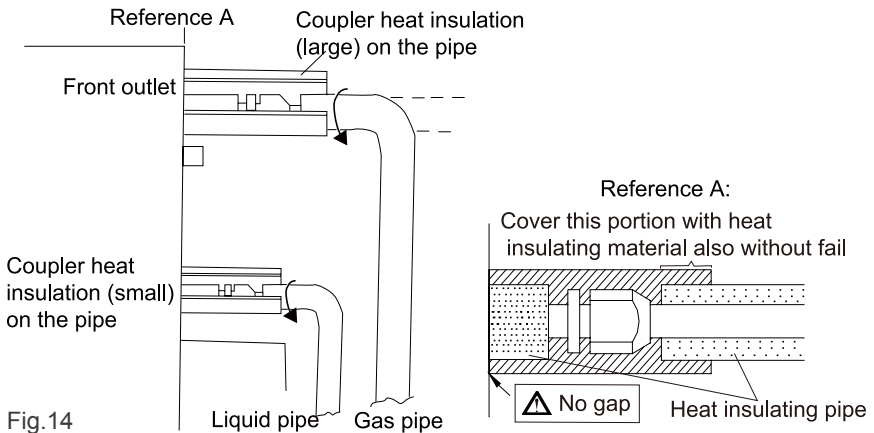

Fig.14

Installation Instructions

Installation of the Drain Hose

a. Installation of Drain Piping



CAUTION!

Install the drain hose in accordance with the instructions in this installation manual and keep the area warm enough to prevent condensation. Problems with the piping may lead to water leaks.

1. Install the drain hose with downward gradient (1/50 to 1/100) and no risers or traps are used for the hose.(Fig.15)
2. Be sure there is no crack or leak on the drain hose to avoid the formation of air pocket. (Fig.15)
3. When the hose is long, install supporters.(Fig.16)
4. Always use the drain hose which has been insulated properly.
5. Use a suitable drain hose, and see Table 3 for its size.
6. There is a drain port on both the left and right sides. Select the drain port to match the local conditions.(Fig.17)
7. When the unit is shipped from the factory, the drain port is defaulted to be the one on the left side (electric box side), the port on right side has been plugged.

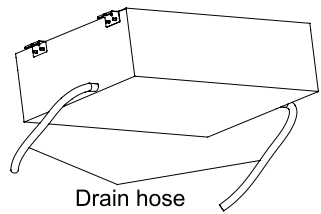
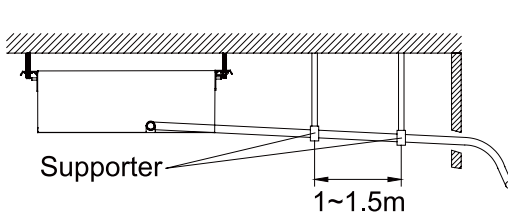
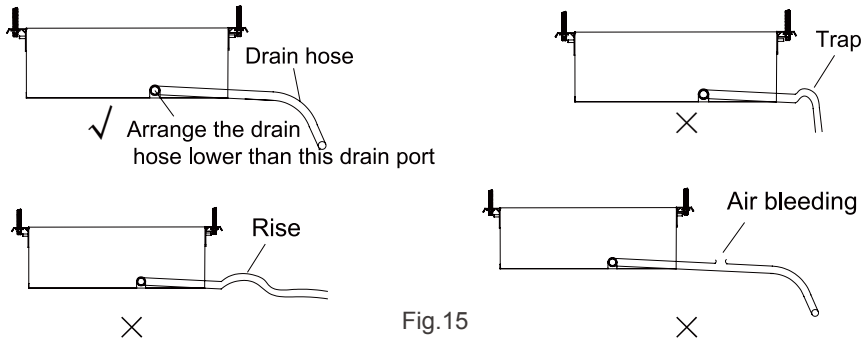

Fig.16

Fig.17

Installation Instructions

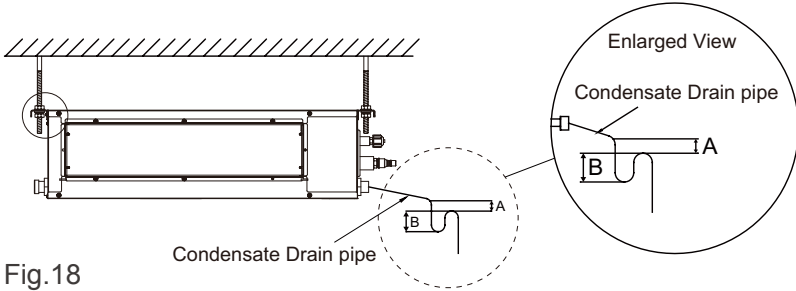

Fig. 18

As the inside of the unit is in the negative pressure status, it is required to set up a backwater elbow. The requirements is: $A=B \geq P/10+20(\text{mm})$
 P is the absolute pressure inside the unit. The unit of the pressure is Pa.

8. When using the drain port on the right side of the unit, reinstall the drain cap to the left side drain port.(Fig.19)

CAUTION!

Always check that the drain cap is installed to the unused drain port and is fastened with the nylon fastener. If the drain cap is not installed, or is not sufficiently fastened by the nylon fastener, water may drip during the cooling operation.

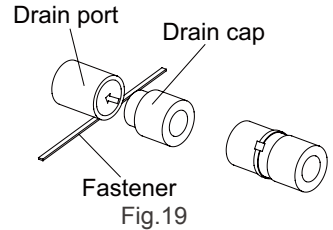

9. Be sure to insulate where the drain port and the drain hose is connected.(Fig.20)
 10. The unused drain port also should be insulated properly.(Fig.21)
 11. There is adhesive on one side of the insulation so that after removing the protective paper over it the insulation can be directly attached to the drain hose.

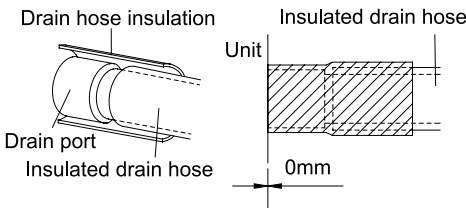

Fig.20

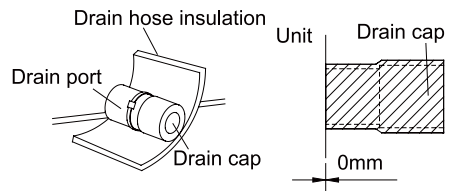

Fig.21

b. Testing of Drain Piping

After piping work is finished, check if drainage flows smoothly.

As shown in the figure, add approximately 1 liter of water slowly into the drain pan and check drainage flow during COOL running.

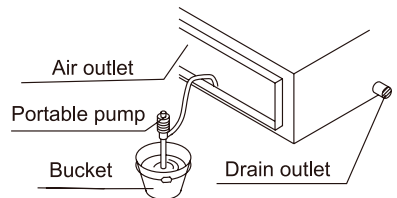

Fig.22

Installation Instructions

Installation of the Duct

a. Dimensions of the Supply Air Outlet/Return Air Inlet

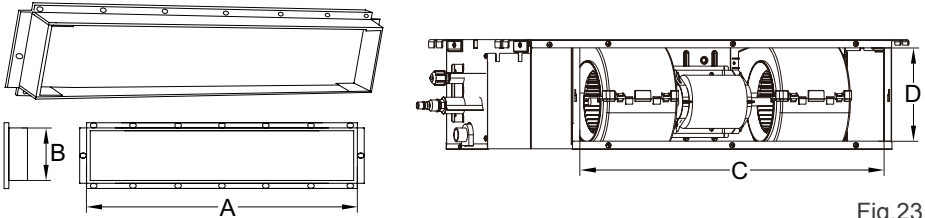

Fig.23

Table 4

Units: mm

Model	Item	Air Supply Outlet		Return Air Inlet	
		A	B	C	D
DBIS-09		538	122	590	170
DBIS-12		538	122	590	170
DBIS-18		808	122	890	170
DBIS-24		1108	122	1190	170

b. Installation of the Air Supply Duct

1. Installation of the rectangular air supply duct

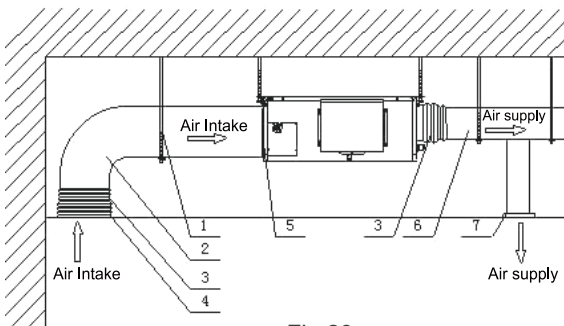

Fig.23

Table 5

No.	Name	No.	Name
1	Hanger	5	Filter
2	Air Intake Pipe	6	Main Air Supply Pipe
3	Canvas Air Pipe	7	Air Supply Outlet
4	Air Intake		

CAUTION!

- The maximum length of the duct means the maximum length of the supply air duct plus the maximum length of the return air duct.
- The duct is rectangular and connected with the air inlet/outlet of the indoor unit. Among all supply air outlets, at least one should be kept open.

Installation Instructions

2. The default installation location of the rectangular flange is at the back and the return air cover plate is at the bottom, as shown in Fig.25

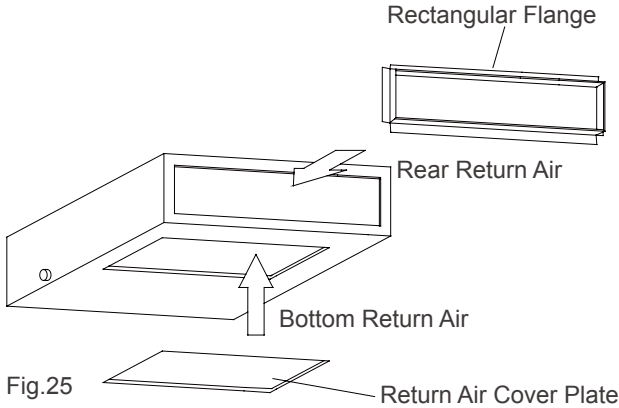

3. If the bottom return air is desired, just change the place of the rectangular flange and the return air cover plate.
4. Connect one end of the return air duct to the return air outlet of the unit by rivets and the other to the return air louver. For the sake of the convenience to freely adjust the height, a cutting of canvas duct will be helpful, which can be reinforced and folded by 8# iron wire.
5. More noise is likely to be produced in the bottom return air mode than the backward return air mode, so it is suggested to install a silencer and a static pressure box to minimize the noise.
6. The installation method can be chosen with considering the conditions of the building and maintenance etc., as shown in Fig.26.

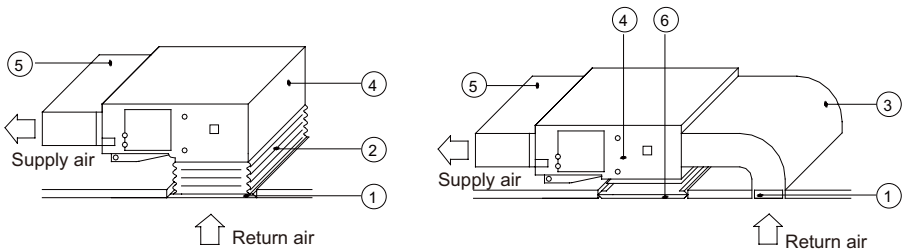

Install the return air duct (a)

Fig.26

Install the return air duct (b)

Table 6 Installation of the return air duct

No.	1	2	3	4	5	6
Name	Return Air Inlet (with filter)	Canvas Duct	Return Air Duct	Indoor unit	Supply Air Duct	Grille

Installation Instructions

Filter Installation

a. Install the air inlet frame

Fasten the air inlet frame on the unit by the screw.

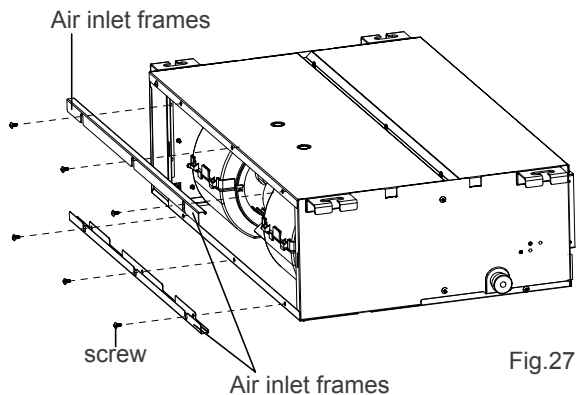

b. Install the filter.

Push the filter into the air inlet frames through the right or left side

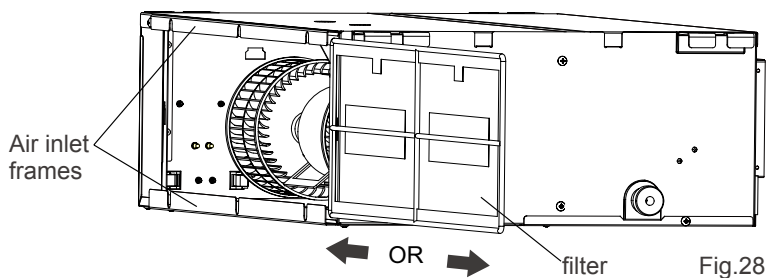

Or, carry the filter from down to upper and then push the filter into the air inlet frames.

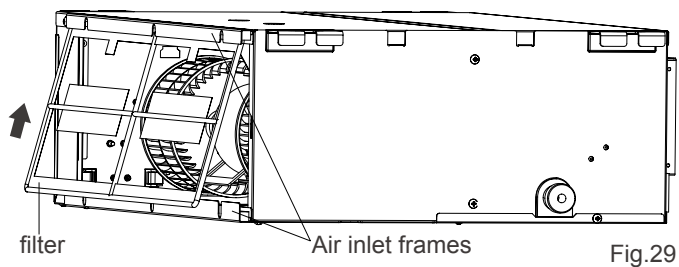

Installation Instructions

Electrical Wiring

a. Wiring Precautions



WARNING!

- Before obtaining access to terminals, all supply circuits must be disconnected.
- The rated voltage of the unit is as shown as table 7.
- Before turning on, verify that the voltage is within the 198~264V range.
- Perform wiring work in accordance with standards so that the air conditioner can be operated safely and positively.

Table 7

Model	Power Supply	Recommended Cord (pieces×sectional area)
DBIS-09	220-240V~,50Hz	4×0.75mm ²
DBIS-12	220-240V~,50Hz	4×0.75mm ²
DBIS-18	220-240V~,50Hz	4×0.75mm ²
DBIS-24	220-240V~,50Hz	4×0.75mm ²

b. Electrical Wiring

1. For solid core wiring (Fig.30)

- (1). Cut the wire end with a wire cutter or wire-cutting pliers, then strip the insulation about 25mm (15/16").
- (2). Using a screwdriver, remove the terminal screw(s) on the terminal board.
- (3). Using pliers, bend the solid wire to form a loop suitable for the terminal screw.
- (4). Shape the loop wire properly, place it on the terminal board and tighten securely with the terminal screw using a screwdriver.

2. For strand wiring (Fig.30)

- (1). Cut the wire end with a wire cutter or wire-cutting pliers, then strip the insulation about 10mm (3/8").
- (2). Using a screwdriver, remove the terminal screw (s) on the terminal board.
- (3). Using a round terminal fastener or pliers, securely clamp a round terminal to each stripped wire end.
- (4). Position the round terminal wire, and replace and tighten the terminal screw with a screwdriver.(Fig.31)

Installation Instructions

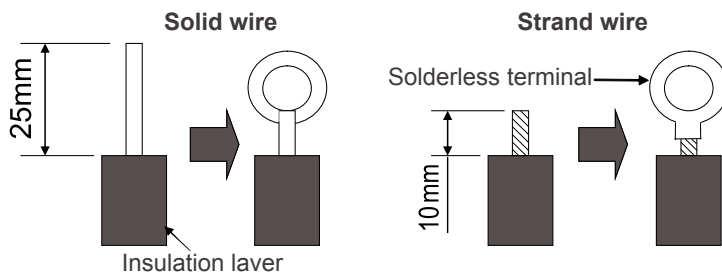

Fig.30

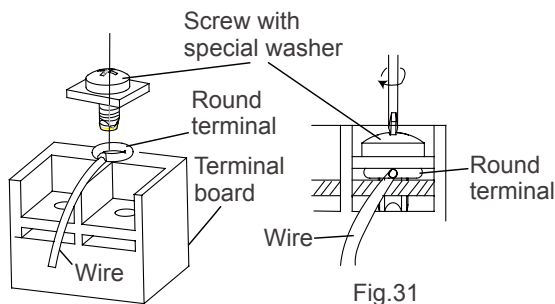

Fig.31

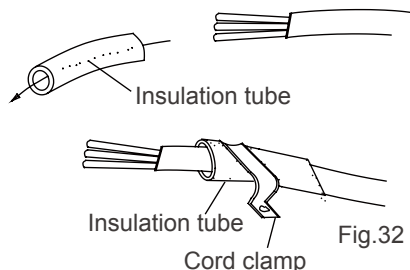

Fig.32

3. How to fix connection cord and power cord by cord clamp

After passing the connection cord and power cord through the insulation tube, fasten it with the cord clamp.(Fig.32)

CAUTION!

- Before starting work, check that power is not being supplied to the outdoor unit.
- Match the terminal block numbers and connection cord colors with those of the indoor unit side.
- Erroneous wiring may cause burning of the electric parts.
- Connect the connection cords firmly to the terminal block. Imperfect installation may cause a fire.
- Always fasten the outside covering of the connection cord with cord clamps. (If the insulator is not clamped, electric leakage may occur.)
- Always connect the ground wire.

Installation Instructions

4. Wiring of the Power Cord



CAUTION!

The power supply for each indoor unit must be uniform.

- Dismantle the cover of the electric box of the indoor unit.
- Let the power cord go through the rubber ring.
- Connect the wiring (communication) through the piping hole of the chassis and the bottom of the appliance upward, then connect the brown wire to the terminal board "3"; black wire(the communication wire) to the terminal board "2"; blue wire to the box. Clamp them with the corresponding wire clamp packed in the chassis.
- Fix the power cord tightly with the binding wire.

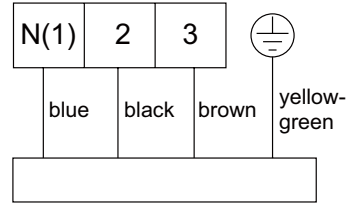

Outdoor unit connection

Fig.33

Installation of the Wired Controller

Refer to the Installation Manual of the wired controller for more details.

Test Running

Trial Operation and Testing

1.The meaning of error codes as shown below:

Table 8

Error Code	Name
CL	Filter clean remind
dF	Defrost or heating oil return
E0	High exhaust temp. protection
E1	Overcapacity protection
E2	Compressor overload protection
E3	Anti-frost protection
HE	Auxiliary heat adhesion protection
L0	Jumper malfunction
L3	Communication malfunction
L7	The communication between indoor unit and wired controller fault
L9	Water full protection
U0	Short/open circuit of indoor environment sensor
U1	Short/open circuit of indoor unit tube sensor
U6	Liquid pipe temp. sensor malfunction
U7	Gas pipe temp. sensor malfunction
U9	Wired controller temp. sensor fault
PC	Mode conflict

Note:

When the unit is connected with the wired controller, the error code will be simultaneously shown on it.

Test Running

2. If match with MULTI-S outdoor unit, after installing the complete units, must test operating when first power on and turn on units to ensure the correct installation.

The steps of test operation is as below:

- A:** Use wired controller to enter the testing operation, then the wired controller display "LL" . This indicates the units start to test operating.
- B:** The test operating is finished when wired controller display change to show temperature from "LL".
- C:** If the wired controller display show "PA" and outdoor unit stop in test operating, indicate the installation has mistake, please check the cable connection and the pipe connection of refrigerant. Correct the mistake and start to test operating again.

Note:

- 1. All the units can operating normally until pass the test operating.
- 2. The method of entering testing operation refer to the manual of the wired controller.

Rated Working Conditions

Table 9 Working Temperature Range

	Indoor side state		Outdoor side state	
	Dry bulb temp. °C	Wet bulb temp. °C	Dry bulb temp. °C	Wet bulb temp. °C
Rated Cooling	27	19	35	24
Max. cooling	32	23	48	26
Min. cooling	21	15	18	-
Rated Heating	20	15	7	6
Max. heating	27	-	24	18
Min. heating	20	15	-15	-16

Indoor unit address inquiry

If match with MULTI-S outdoor unit, when units has malfunction and need to inquire the address to maintainance, refer to the manual of the wired controller for the operation method.

Error Analysis

If your conditioning unit runs abnormally, please check the following items before contact the maintenance serviceman.

Table 10

Errors	Possible causes
Failed starup	<ol style="list-style-type: none">1. The power supply is not connected.2. Electrical leakage of air-conditioning unit causes tripping of the leakage switch.3. The operating keys are locked.4. Voltage is too low.
Stop after a short while of opration	The air inlet/outlet of the indoor/outdoor unit is clogged.
Poor cooling effect	<ol style="list-style-type: none">1. The air filter is dirty or blocked.2. There is heat source or too many people inside the room.3. The door or window is open.4. There is obstacle at the air intake or outlet.5. The set temperature is too high.6. There is refrigerant leakage.7. The performance of room temperature sensor becomes worse.
Poor heating effect	<ol style="list-style-type: none">1. The air filter is dirty or blocked.2. The door or window is not firmly closed.3. The set room temperature is too low .4. There is refrigerant leakage.

Note:

If the air conditioner still runs abnormally after the above check and handling, please contact the maintenance serviceman at the local appointed service center.

Maintenance



CAUTION!

Take notice of the following items before clean your air conditioning unit.

1. Cut off the main power supply before contact any wiring device.
2. Only when the unit is turn off and the main power supply is cut off, can the unit be cleaned; otherwise it would cause an electric shock or injury.
3. Do not wash the unit with water; or it may cause an electric shock.
4. During the cleaning, remember to use the stable standing platform daily maintenance.

● How to clean the filter

1. Never dismantle the air filer except for cleaning; otherwise it may cause some error.
2. When the air conditioning unit is used under the environment with heavy dust, the air filter should be cleaned often (generally once every two weeks).

● Maintenance before seasonal use

1. Check if the inlet/outlet of the indoor/outdoor unit is clogged.
2. Check if the earthing is in good condition.
3. Check if the wiring is in good condition.
4. Check if the indicating lamp of the wired controller blinks after it is energized.

Note: If there is something abnormal, please consult the after-sales serviceman.

● Maintenance after seasonal use

1. Let the air conditioning unit run for half day under the fan mode to dry the inside of the unit.
2. If the unit is not to be used for a long time, please shut off the main power supply for energy conservation, at the same time, the power lamp of the wired control will go off.

